

HAWK-C

MEDIUM WAVE INFRARED DETECTOR

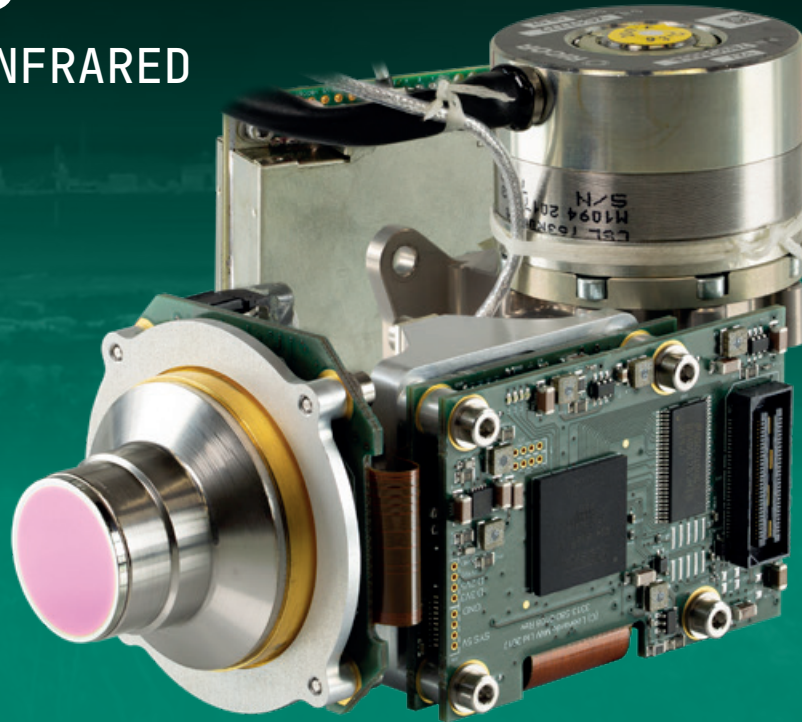

The Hawk-C Medium Wave Infrared (MWIR) detector is a compact 640 x 512 Mercury Cadmium Telluride (MCT) Integrated Detector Cooler Assembly (IDCA).

To reduce size, weight and power the MCT is operated warmer than the standard Hawk IDCA, allowing the use of lower powered coolers and promoting longer engine life.

Hawk-C is available either as an IDCA with a similar electrical interface to Hawk or with proximity electronics.

The proximity electronics also provide the IDCA with drive signals and sensitive power supplies.

MAIN FEATURES

- Medium wave 3-5 μ m
- Small element 16 μ m pitch enables miniaturisation of the Dewar assembly and optics
- High electro-optic performance with low crosstalk, automatic anti-blooming at the pixel level and excellent sensitivity
- Higher operating temperature
- Longer cooler life
- Less in-service support
- Lower through-life cost
- Flexible windowing gives enhanced frame rates over selected areas of the array
- Variable gain via user selectable integration capacitors
- Snapshot or rolling readout operation
- Simple to use with proximity electronics available

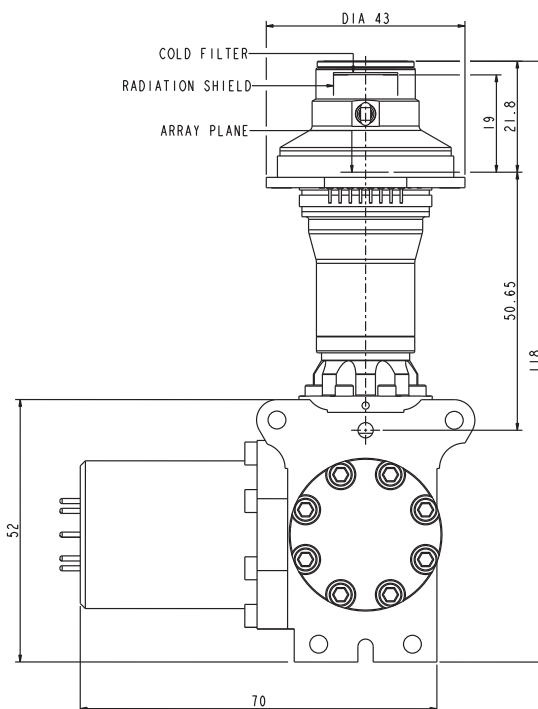
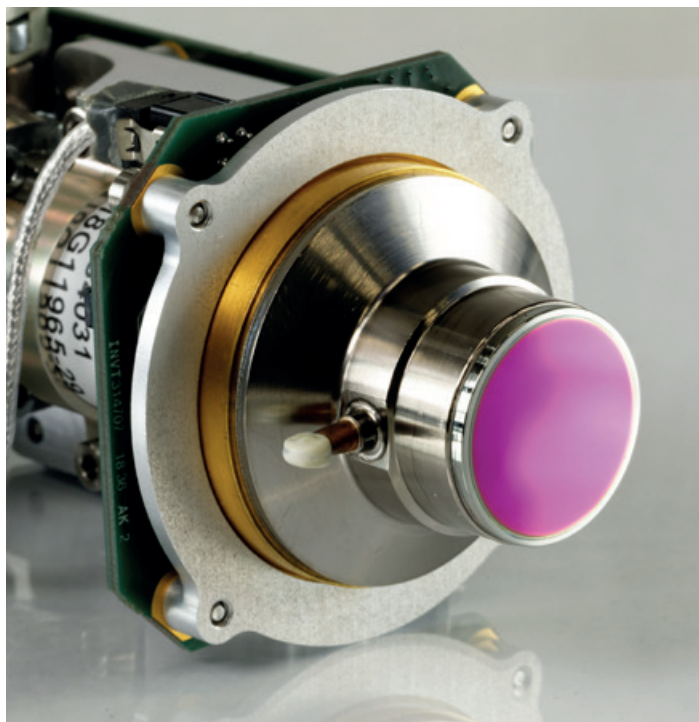

TECHNICAL SPECIFICATION

Format

Array	640 x 512 pixels
Pixel Pitch	16µm
Active Area	10.24 x 8.19mm

Typical Performance

NETD	20mK (300K, F/5.5, 50% well fill)
Pixel Operability	99.9% at 110K
Modes	Snapshot or rolling reset
Charge Capacity	7 x 10 ⁶ electrons
Number of Outputs	4
Pixel Rate	10MHz per output
Array Temp	110K
F/#	5.5 (others available on request)
Window Material	Germanium
Window Thickness	1.25mm
Cold Filter Material	Silicon
Cold Filter Thickness	0.4mm

IDCA With K563 Cooler (Typical Values, 20°C Amb)

Mass	384g (with CCM)
Cooler Power supply	12V
Power Consumption	3W steady state 16W cooldown
Cool down time	180 sec 20°C amb
Operating Temp Range	-35°C to +65°C

Proximity Electronics (Optional)

Power supply	5V
Power Consumption	<2W
Interface	LVDS, CameraLink compatible
Weight IDCA & proximity electronics	435g

Options Available On Request

Cooler	Other Cooler options may be available on request
--------	--

For more information:
infomarketing@leonardo.com

Leonardo Electronics
 First Avenue-Millbrook Industrial Estate-Southampton-Hampshire-SO15 0LG-
 United Kingdom-T +44 (0) 2380 702300

This publication is issued to provide outline information only and is supplied without liability for errors or omissions.
 No part of it may be reproduced or used unless authorised in writing.
 We reserve the right to modify or revise all or part of this document without notice.

2024 © Leonardo UK Ltd

LDO_UK023_00178 04-24