

## LONG WAVE INFRARED DETECTOR

The company designs, develops and manufactures Infrared (IR) detectors at its dedicated facility in Southampton, UK. With a reputation for providing customers with the best in high performance and cost-effective technology for IR camera systems, we offer a unique level of expertise.

The Eagle Long Wave Infrared (LWIR) detector is a 640 x 512 Mercury Cadmium Telluride (MCT) Integrated Detector Cooler Assembly (IDCA). The Eagle LWIR detector is designed for very high performance imaging in the 8 - 10 $\mu$ m waveband.

Using the MCT process, the Eagle LWIR detector provides the highest environmental integrity along with the superior performance of focal plane detectors.

### MAIN FEATURES

- Snapshot or rolling reset operation
- Simple to use
- Long Wave (LW) 8-10 $\mu$ m
- High electro-optic performance with low crosstalk, automatic anti-blooming at the pixel level and excellent sensitivity
- Windowing gives enhanced frame rates over selected areas of the array
- Highest LW technology performance available in the world
- Longest LW technology DRI ranges
- Reduced stare time, less motion blur than QWIP detectors
- High performance in low scene temperature.

## KEY BENEFITS

- Low cost
- High resolution
- High frame rate
- High sensitivity.

## TECHNICAL SPECIFICATIONS

Format Array	640 x 512 pixels
Pixel Pitch	24µm
Active Area	15.36 x 12.29mm

TYPICAL PERFORMANCE	
NETD (median)	20mK
Pixel Operability	>99.8%

INTERFACE PARAMETERS	
Modes	Snapshot or rolling reset
Configuration Control	Parallel interface
Output Voltage Range	2.2V
Charge Capacity	1.8 x 10 <sup>7</sup> electrons
Number of Outputs	4
Pixel Rate	Up to 10MHz per output
Intrinsic MUX noise	50µV rms
Array Operating Temperature	Up to 90K
Nominal Operating Voltage	7V
Minimum Pins for Operation	13
Number of Input Clocks	1
Window Material	Germanium
Window Thickness	1.73mm
Cold Filter Material	Silicon
Cold Filter Thickness	0.4mm

IDCA	
Weight	<750g
Power Consumption	<10W steady state
Cooling Engine	Rotary Stirling engine
Operating Temperature Range	-40°C to +70°C

LINEAR ENGINE VARIANT	
Weight	950g
Power Consumption	<15W steady state
Cooling Engine	Linear Stirling engine
Operating Temperature Range	-40°C to +70°C

## IDCA

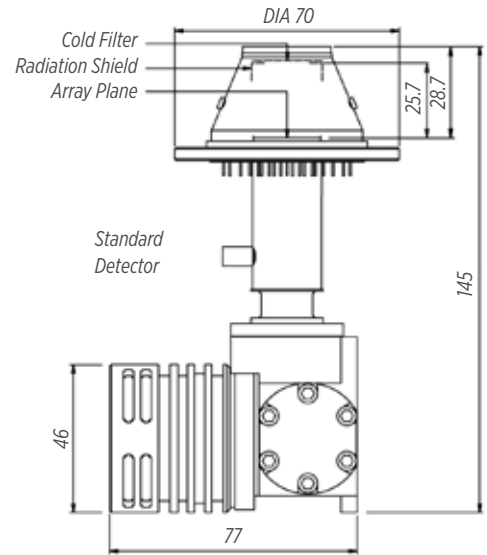

## Linear Engine Variant

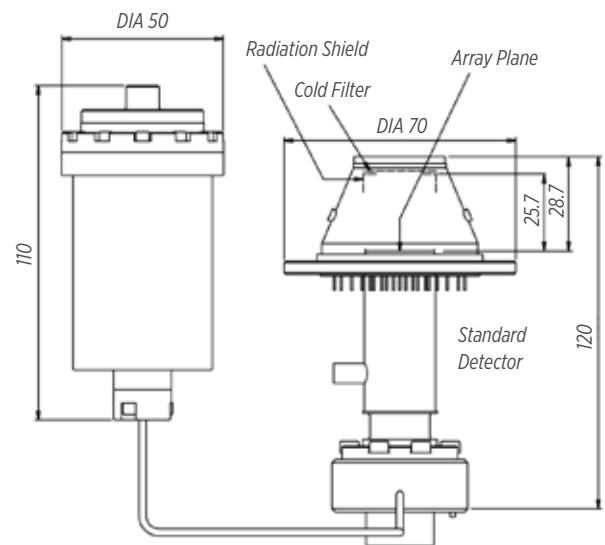

All dimensions in mm