

BLACK SNAKE

TOWED SONAR FOR TORPEDO DCL



BLACK SNAKE is a light and compact towed array SONAR purposely designed to be effective against attacking torpedoes.

It has been conceived as a complement of the C310 Torpedo Countermeasure System in the frame of SURVIVAL, the most modern, light and highly effective autonomous anti-Torpedo Defence System for any type of surface ship.

BLACK SNAKE is a towed array SONAR operating in 'passive' mode, especially designed for torpedo detection.

The use of a patented, innovative beamforming algorithm within a suitable working frequency bandwidth allows achieving good performance in terms of detection distances and bearing measurement accuracy even in presence of modern very silent torpedoes.

The particular design results in winch footprint strong reduction, which in turns allows BLACK SNAKE installation even on small crafts.

BLACK SNAKE executes the following main functions:

- Detection of noise source/s and eventual torpedo active transmissions
- Fast Classification of the noise source Torpedo/not torpedo
- Localisation of the noise source (bearing only).

A patented, innovative device allows the left/right ambiguity solving in very short time without using hydrophones-triplets or asking the towing ship to execute manoeuvre to induce movements on the towed array.

This gives two advantages on the system: reduced dimensions of the towed body and reduced time to obtain the torpedo-classification information.

Both these two advantages are very important since:

- Smaller dimension of the towed body means smaller diameter of towing cable and dimensions of the winch
- Fast classification is very important due to the shorter detection distance that can be expected as a consequence of the evolution of modern torpedoes that are day by day reducing their radiated noise.

As the torpedo attack may come from any direction, BLACK SNAKE provides a fully panoramic acoustic coverage; only a small sector oriented towards the towing ship is influenced by the presence of ship radiated noise and presents a performance reduction.

BLACK SNAKE surveillance is permanent, also during the escaping manoeuvre, and this allows, if necessary, a second reaction to torpedo re-attacks.



By default, BLACK SNAKE generates an Automatic Torpedo Alarm in order to reduce reaction time; however, when working in “Manual” Mode, it allows an operator to manually input a torpedo alarm. Specific SONAR analysis widgets are available to the operator allowing detailed and effective signal analysis. BLACK SNAKE is directly interfaced with the Reaction Sub System to carry out the optimized reaction and is fitted for integration with any ship Combat Management System.

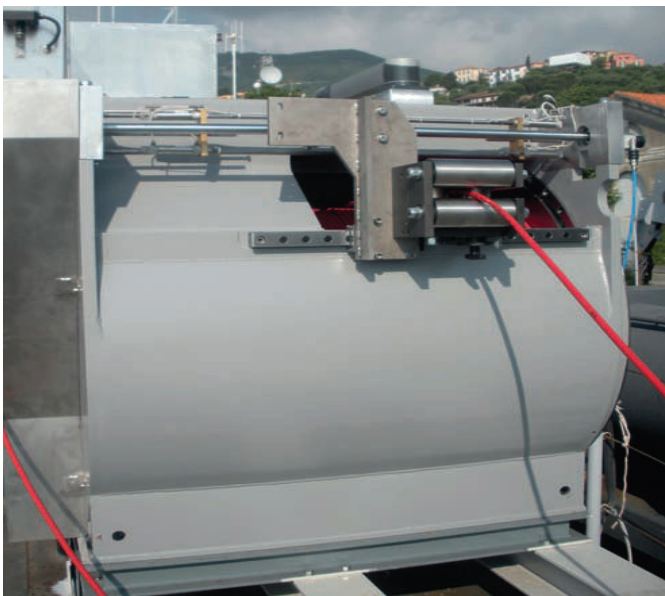

For more information:
 infomarketing@leonardo.com
Electronics Division
 Via di Levante, 48
 57124 Livorno-Italy
 Tel. +39 0586 840111
 Fax: +39 0586 854060



leonardo.com



ADVANCED BEAMFORMING

The use of the advanced innovative beam-forming algorithms allows achieving very good performances in terms of beam-width and bearing measurement accuracy using a reduced number of transducers, thus contributing to reduce the overall dimensions of the towed body.

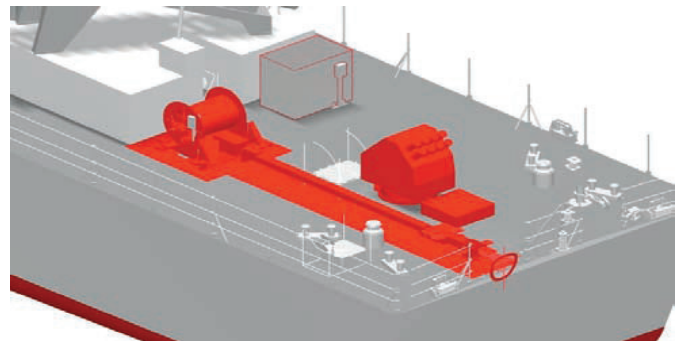

COMPOSITION

BLACK SNAKE is composed by the following devices:

- 2x Screens Processing Unit
- Compact Deploy and Recovery device (Winch)
- Towing Electromechanical Cable (Fiber Optic)
- Vibration Insulating Module
- Towed Array
- Stabilizers.

TECHNICAL SPECIFICATIONS

DIMENSION

Winch footprint	Less than 1.5m x 1.5m
Towed body	Ø < 60mm, length < 5m
Towing cable	Ø = 16mm, length = 600m

This publication is issued to provide outline information only and is supplied without liability for errors or omissions. No part of it may be reproduced or used unless authorised in writing. We reserve the right to modify or revise all or part of this document without notice.

2022 © Leonardo S.p.A.

MM08735 07-22

